

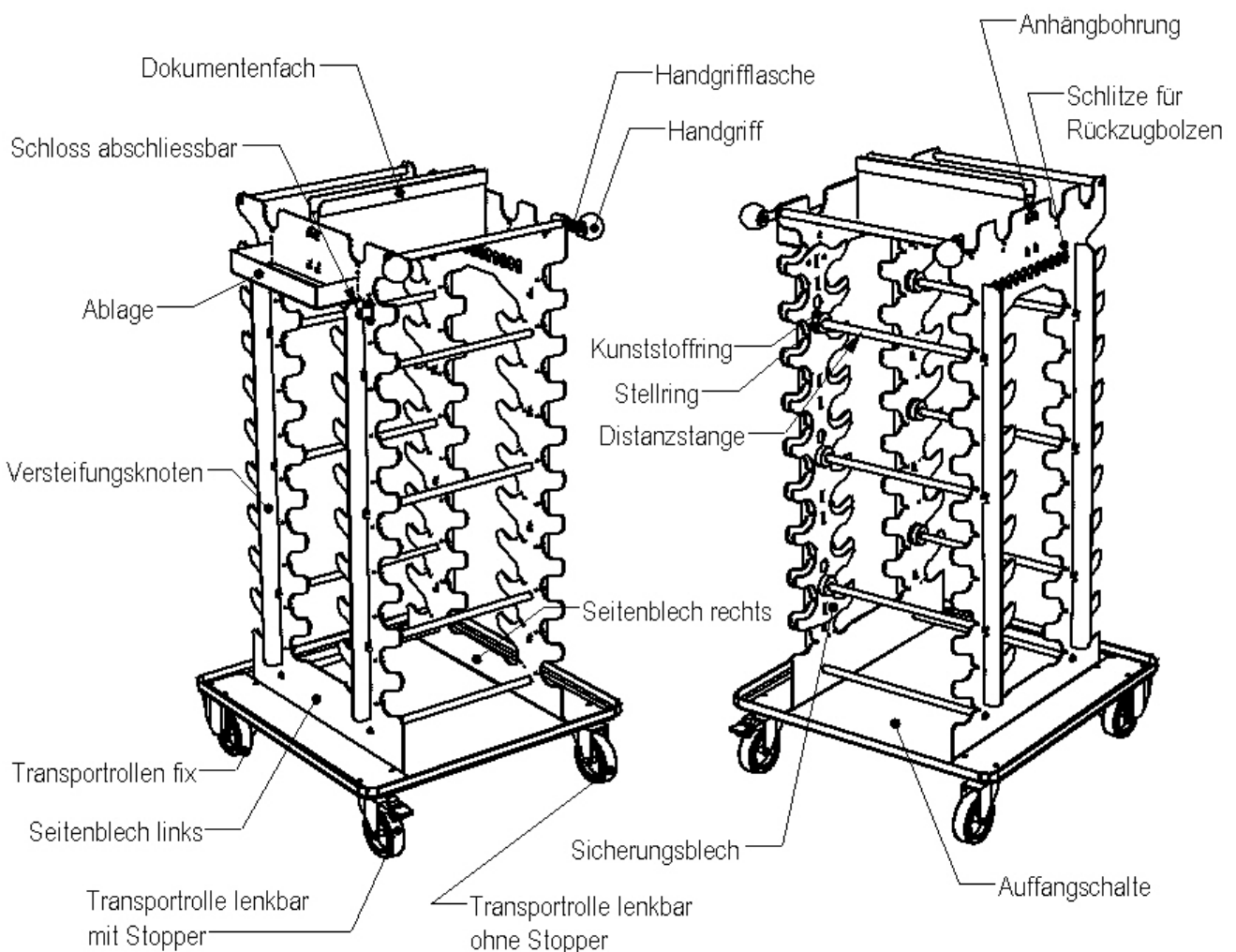

S-TOOLING
the best solution.

Technische Zeichnung & Details

Technical Drawing & Specifications



tool caddy

Technische Daten Specifications	CAT 40 / HSK 63		CAT 50 / HSK 100	
	Maximale Werkzeuglänge Max tool length	400 mm	15.88 in	530 mm
Werkzeugdurchmesser (Std.) Tool diameter (std)	90 mm	3.54 in	130 mm	5.12 in
Werkzeugdurchmesser (variabel) Tool diameter (variable)	160 mm	6.3 in	160 mm	6.3 in
Werkzeugdurchmesser (oben) Tool diameter (top)			250 mm	9.84 in
Traglast Weight capacity	600 kg	1320 lb	750 kg	1650 lb
Stellfläche Floor space	655 x 655 mm	26 x 26 in	800 x 864 mm	31.5 x 34 in
Höhe Height	1082 mm	49.5 in		49.5 in
Gewicht Weight	52.5 kg	115 lb	67.5 kg	148 lb
Aufnahmen Pockets	82 tools		66 tools	
Verriegelung (Std.) Locking (std)	18 tools		14 tools	
Verriegelung (optional) Locking (optional)	72 tools		56 tools	

